

Signal Bandwidth vs. Resolution for Analog Video

by Ferenc Barany

INTRODUCTION

Unlike traditional signals such as audio, where information is carried in the amplitude of the signal over time, video signals carry the image information in both the value and position of each image pixel over time. The large amount of information embedded in the video signal makes its spectrum a lot wider compared with similar baseband signals such as audio. This requires special attention when designing video systems to ensure that the information contained in the video signal is transmitted from the source to the receiver with minimum degradation of the image quality. This application note provides an overview of video signal bandwidth requirements and describes how to estimate the minimum and maximum frequencies from its spectrum. Table 1 and Table 2 provide the calculated values for signals with the most common resolutions on the market.

ANALOG VIDEO SIGNAL SPECTRUM

Since the content of an image varies significantly in terms of bandwidth, the spectrum of a video signal can be compared to the spectrum of Gaussian noise, which is flat between dc and infinity. Because the bandwidth of the video signal is limited, the highest frequency component from its spectrum, f_{MAX} , is determined by the system's capability to capture the smallest details of the image (see Figure 1).

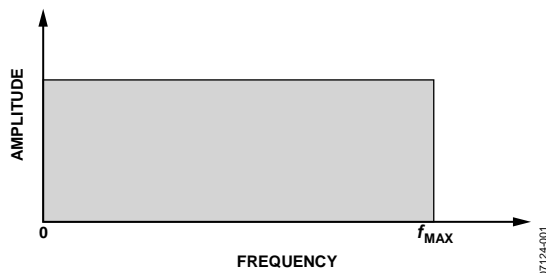

Figure 1. Video Signal Spectrum.

To preserve the image quality, the video system needs to have a flat frequency response from DC up to the highest frequency component in the video signal's spectrum. To ensure this, dc coupling is commonly used between different stages within the same system. However, for safety reasons, ac coupling is the preferred method when connecting video circuitry from different systems. Employing ac coupling is advantageous because it avoids large dc currents caused by the direct connection of circuits operating with different power supply voltages. Because the ac coupling capacitor blocks the dc component of the signal, the designer must employ dedicated

circuitry to restore the video signal's dc component, usually a dc clamping circuit (see Figure 2).

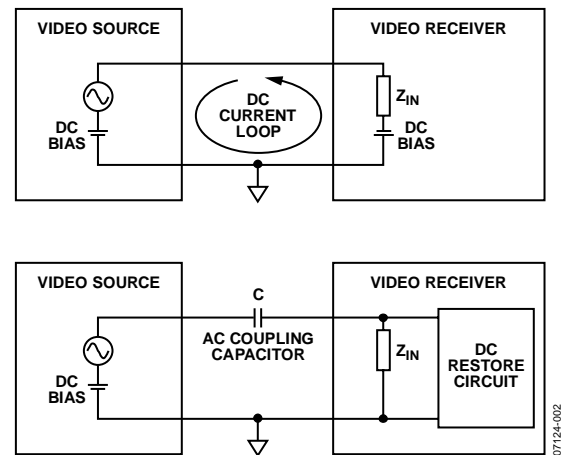

Figure 2. AC Coupling in Video Systems

The high-pass filter formed by the ac coupling capacitor and the equivalent input impedance of the dc restore circuit attenuates low frequency components of the signal. This leads to an overall band-pass frequency response, which needs to be flat between the minimum and the maximum frequency components from the video signal's spectrum as shown in Figure 3.

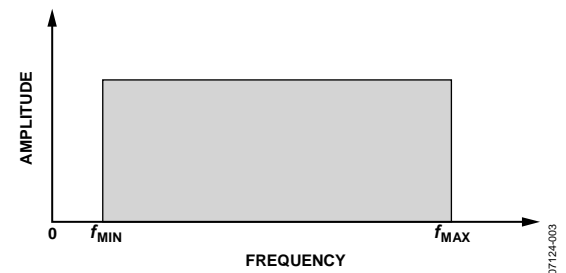

Figure 3. AC Coupled Video Signal Spectrum

Since the minimum and maximum video frequencies are heavily dependent on the video signal characteristics, this application note describes how to calculate these components for the most common resolutions including SDTV, HDTV, and PC graphics.

MAXIMUM VIDEO FREQUENCY

The component with the highest frequency from the video signal's spectrum dictates the bandwidth of the signal. This corresponds to the smallest picture detail that can be reproduced. During the scanning process, any image is divided into

pixels, some of them active (visible on the screen), and some of them blank (invisible on the screen) as shown in Figure 4.

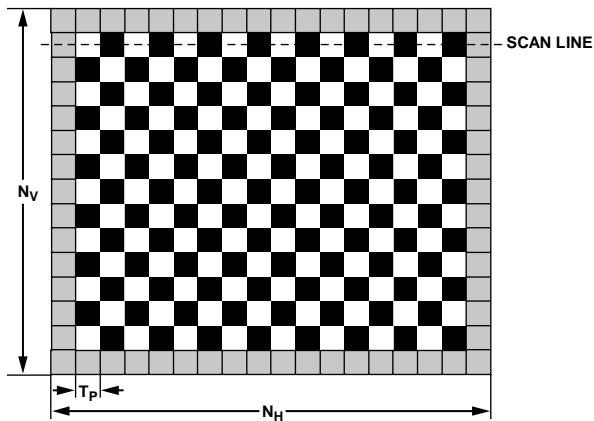

LEGEND: OR = ACTIVE PIXELS (VISIBLE ON THE SCREEN)
 = BLANK PIXEL (NOT VISIBLE ON THE SCREEN)

Figure 4. Pixels in a Scanned Image

07124-004

Considering that the amount of time required to scan all the pixels from an image (active and blank) is T_V , the duration of a pixel can be calculated using:

$$T_p = \frac{T_V}{N_H \times N_V}$$

where:

T_p is the duration of a single pixel.

N_H and N_V are the total number of horizontal and vertical pixels including the active and blank pixels.

T_V is the time required to scan all pixels from an image.

Considering the scanned image from Figure 4, where adjacent pixels have different values, the resulting video signal is a square wave.

A complete cycle of the square wave corresponding to the maximum video frequency is equal to the duration of two adjacent pixels. Therefore, the maximum video frequency becomes

$$f_{MAX} = \frac{1}{2 \times T_p} = \frac{N_H \times N_V}{2 \times T_V} = \frac{N_H \times N_V \times f_V}{2}$$

where:

$$f_V = \frac{1}{T_V} \text{ is the vertical refresh rate.}$$

MINIMUM VIDEO FREQUENCY

When ac coupling is used, it is important to determine the minimum video frequency that needs to be passed by the system unattenuated. While the maximum video frequency represents the smallest detail that can be reproduced, the minimum video frequency is determined by the largest image detail. As the largest detail is a pixel with the size of the whole image, the total resolution is equal to 1 ($N_H = N_V = 1$). In this case the pixel duration is $T_p = T_V$. Since a full cycle of the minimum video frequency contains only one pixel, the minimum video frequency, F_{MIN} , is actually given by the vertical refresh rate

$$f_{MIN} = \frac{1}{T_V} = f_V$$

CONCLUSION

Because high quality video has become widely available, careful analysis of the system bandwidth needs to undertaken to ensure that the image quality is not degraded. The calculation of the minimum and maximum video frequencies for a given video signal enables the design engineer to choose the correct circuitry to ensure the best picture quality for all of the supported video standards and interfaces.

The values of the minimum and maximum video frequencies corresponding to the most common TV and PC graphics standards are listed in Table 1 and Table 2, respectively.

References

1. Keith, Jack. 2005. *Video Demystified*. 4th edition, Elsevier.
2. *VESA Monitor Timing Specifications*, Version 1.0, Rev. 0.8, September 1998.

Table 1. Minimum and Maximum Video Frequencies for TV Standards

Standard	Active Resolution (Pixels)	Total Resolution $N_H \times N_V$ (Pixels)	Aspect Ratio	Scanning Method	Vertical Refresh Rate (Hz)	Minimum Video Frequency (Hz)	Maximum Video Frequency (MHz)
480i	720 × 480	858 × 525	4:3	Interlaced	30	30	6.76
	960 × 480	1144 × 525	16:9	Interlaced	30	30	9.01
480p	720 × 480	858 × 525	4:3	Progressive	60	60	13.51
576i	720 × 576	864 × 625	4:3	Interlaced	25	25	6.75
	960 × 576	1152 × 625	16:9	Interlaced	25	25	9.00
576p	720 × 576	864 × 625	4:3	Progressive	50	50	13.50
720p	1280 × 720	1650 × 750	16:9	Progressive	60	60	37.13
1080i	1920 × 1080	2200 × 1125	16:9	Interlaced	30	30	37.13
	1920 × 1080	2376 × 1250	16:9	Interlaced	25	25	37.13
1080p	1920 × 1080	2200 × 1125	16:9	Progressive	60	60	74.25
	1920 × 1080	2376 × 1250	16:9	Progressive	50	50	74.25

Table 2. Minimum and Maximum Video Frequencies for PC Graphics Standards

Standard	Active Resolution (Pixels)	Total Resolution $N_H \times N_V$ (Pixels)	Aspect Ratio	Scanning Method	Vertical Refresh Rate (Hz)	Minimum Video Frequency (Hz)	Maximum Video Frequency (MHz)
VGA	640 × 480	800 × 525	4:3	Progressive	60	60	12.60
	640 × 480	832 × 520	4:3	Progressive	72	72	15.58
	640 × 480	840 × 500	4:3	Progressive	75	75	15.75
	640 × 480	832 × 509	4:3	Progressive	85	85	18.00
SVGA	800 × 600	1024 × 625	4:3	Progressive	56	56	17.92
	800 × 600	1056 × 628	4:3	Progressive	60	60	19.90
	800 × 600	1040 × 666	4:3	Progressive	72	72	24.94
	800 × 600	1056 × 625	4:3	Progressive	75	75	24.75
	800 × 600	1048 × 631	4:3	Progressive	85	85	28.10
XGA	1024 × 768	1344 × 806	4:3	Progressive	60	60	32.50
	1024 × 768	1328 × 806	4:3	Progressive	70	70	37.46
	1024 × 768	1312 × 800	4:3	Progressive	75	75	39.36
	1024 × 768	1376 × 808	4:3	Progressive	85	85	47.25
SXGA	1280 × 1024	1688 × 1066	5:4	Progressive	60	60	53.98
	1280 × 1024	1688 × 1066	5:4	Progressive	75	75	67.48
	1280 × 1024	1728 × 1072	5:4	Progressive	85	85	78.73
UXGA	1600 × 1200	2160 × 1250	4:3	Progressive	60	60	81.00
	1600 × 1200	2160 × 1250	4:3	Progressive	65	65	87.75
	1600 × 1200	2160 × 1250	4:3	Progressive	70	70	94.50
	1600 × 1200	2160 × 1250	4:3	Progressive	75	75	101.25
	1600 × 1200	2160 × 1250	4:3	Progressive	85	85	114.75

AN-944

NOTES